

SCXI-1326 HIGH-VOLTAGE TERMINAL BLOCK

This guide describes how to use and install the SCXI-1326 high-voltage terminal block with the SCXI-1162, the SCXI-1163, the SCXI-1162HV, and the SCXI-1163R modules.

Introduction

The SCXI-1326 terminal block is a shielded board with supports to connect it to the module front connector.

The terminal block has 48 screw terminals for easy signal connections. The terminals labeled *VCC* on the SCXI-1326 terminal block are not used with the SCXI-1162HV or the SCXI-1163R. The terminals labeled *GND* are not used on the SCXI-1162. The screw terminals are arranged in eight groups of six terminals. Each group is isolated from the other groups. The six terminals in a group consist of a *VCC*, *GND*, and four channels. The use of these terminals is module dependent and is summarized in the following table.

Terminals	SCXI Modules			
	SCXI-1162	SCXI-1162HV	SCXI-1163	SCXI-1163R
VCC	Power/reference voltage	Not used	Power supply (5 V \pm 0.5 V referenced to GND)	Not used
GND	Not used	Ground reference	Ground	Common pole
CHAN(x)	Digital input	Input signal	Digital output	Relay inputs

What You Need to Get Started

To set up and use your SCXI-1326 terminal block kit, you will need the following components:

- SCXI-1326 High-Voltage Terminal Block Installation Guide*
- SCXI-1326 high-voltage terminal block
- SCXI chassis
- SCXI-1162, SCXI-1163, SCXI-1162HV, or SCXI-1163R module
- No. 1 and No. 2 Phillips-head screwdrivers
- 1/10 in. and 1/4 in. flathead screwdrivers
- Needle-nose pliers
- Wire cutter
- Wire insulation stripper

Safety Information



Cautions *DO NOT OPERATE THE DEVICE IN AN EXPLOSIVE ATMOSPHERE OR WHERE THERE MAY BE FLAMMABLE GASES OR FUMES.*

KEEP AWAY FROM LIVE CIRCUITS. Do not remove equipment covers or shields unless you are trained to do so. If signal wires are connected to the device, hazardous voltages may exist even when the equipment is turned off. To avoid a shock hazard, do not perform procedures involving cover or shield removal unless you are qualified to do so and disconnect all field power prior to removing covers or shields.

Equipment described in this document must be used in an Installation Category II environment per IEC 664. This category requires local level supply mains-connected installation.

DO NOT OPERATE DAMAGED EQUIPMENT. The safety protection features built into this device can become impaired if the device becomes damaged in any way. If the device is damaged, turn the device off and do not use until service-trained personnel can check its safety. If necessary, return the device to National Instruments for service and repair to ensure that its safety is not compromised.

Do not operate this equipment in a manner that contradicts the information specified in this document. Misuse of this equipment could result in a shock hazard.

Terminals are for use only with equipment that has no accessible live parts.

DO NOT SUBSTITUTE PARTS OR MODIFY EQUIPMENT. Because of the danger of introducing additional hazards, do not install unauthorized parts or modify the device. Return the device to National Instruments for service and repair to ensure that its safety features are not compromised.

When using the device with high common-mode voltages, you MUST insulate your signal wires for the highest input voltage. National Instruments is NOT liable for any damages or injuries resulting from inadequate signal wire insulation. Use only 26-14 AWG wire with a voltage rating of 300 V and 60° C for measuring 250 to 300 V.

When connecting or disconnecting signal lines to the SCXI terminal block screw terminals, make sure the lines are powered off. Potential differences between the lines and the SCXI ground create a shock hazard while you connect the lines.

Connections, including power signals to ground and vice versa, that exceed any of the maximum signal ratings on the SCXI device can create a shock or fire hazard or can damage any or all of the boards connected to the SCXI chassis, the host computer, and the SCXI device. National Instruments is NOT LIABLE FOR ANY DAMAGES OR INJURIES resulting from incorrect signal connections.

If high voltages (≥ 30 Vrms and 42.4 V peak or 60 VDC) are present, YOU MUST CONNECT A SAFETY EARTH GROUND WIRE TO THE TERMINAL BLOCK SAFETY GROUND SOLDER LUG, shown in Figure 1. This complies with safety agency requirements and protects against electric shock when the terminal block is not connected to the chassis. To connect the safety earth ground to the safety ground solder lug, run an earth ground wire in the cable from the signal source to the terminal block. National Instruments is NOT liable for any damages or injuries resulting from inadequate safety earth ground connections.

Do not loosen or re-orient the safety ground solder lug hardware when connecting the safety ground wire; to do so reduces the safety isolation between the high voltage and safety ground.

Signal Connection



Note

Refer to the Safety Information section before removing equipment covers or connecting or disconnecting any signal wires.

When connecting your signals to the SCXI-1326, follow the labeling on the SCXI-1326 for the appropriate module, as indicated in Figure 2.

To connect the signal to the terminal block, perform the following steps, referring to Figures 1 and 2 as necessary:

1. Unscrew the top cover screws and remove the cover.
2. Loosen the strain-relief screws and remove the strain-relief bar.

3. Run the signal wires through the strain-relief opening. You can add insulation or padding if necessary.
4. Prepare your signal wire by stripping the insulation no more than 7 mm.
5. Connect the wires to the screw terminals by inserting the stripped end of the wire fully into the terminal. No bare wire should extend past the screw terminal. Exposed wire increases the risk of shorting and causing a failure.
6. Tighten the screws to a torque of 5–7 in.-lb.
7. Connect safety earth ground to the safety ground solder lug. Refer to the *Safety Information* section for connection information.
8. Reinstall the strain-relief bar and tighten the strain-relief screws.
9. Reinstall the top cover and tighten the top cover screws.
10. Connect the terminal block to the module front connector as explained in the *Installation* section later in this guide.

Figure 1 shows the SCXI-1326 terminal block parts locator diagram.

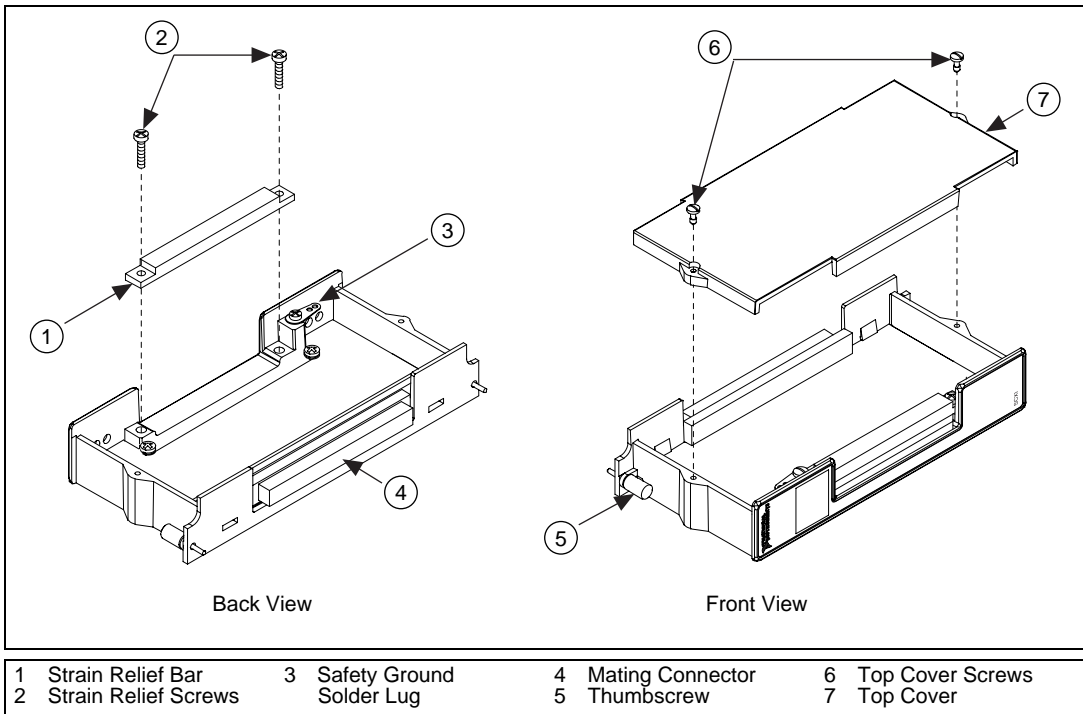

Figure 1. SCXI-1326 Parts Locator Diagram

Figure 2 shows the SCXI-1326 signal connections.

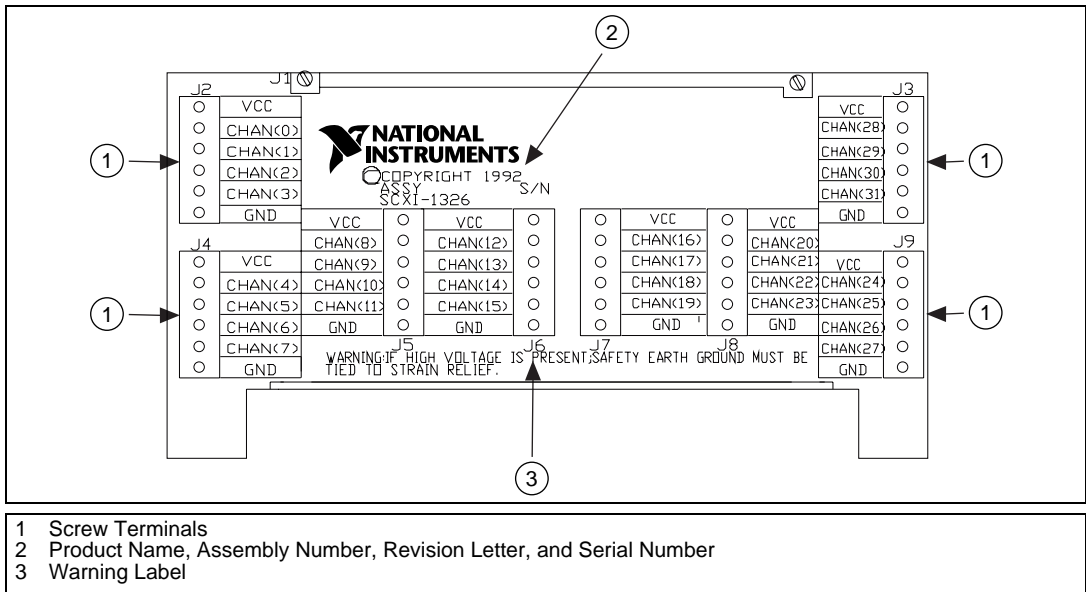

Figure 2. SCXI-1326 Signal Connections

Installation

To connect the terminal block to the SCXI module front connector, perform the following steps:

1. Connect the module front connector to its mating connector on the terminal block.
2. Tighten the top and bottom thumbscrews on the back of the terminal block to hold it securely in place.

Cleaning the Terminal Block

Clean the terminal block by brushing off light dust with a soft, nonmetallic brush. Remove other contaminants with deionized water and a stiff nonmetallic brush. The unit must be completely dry and free from contaminants before returning to service.



321928A-01

Aug98